

## **Installation Instructions**

*Wood Frame & Foam Rail*

### **Western Region**

909-605-6419

### **East/Central Region**

888-833-3329

Manufacturing – Ontario CA, Winnebago, MN, and Greenville, TN, Olive Branch, MS

## **INDEX**

<b>1. SAFETY</b>	<b>Page 3</b>
<b>2. RECEIVING INSTRUCTIONS</b>	<b>Page 3</b>
<b>3. UNLOADING PRODUCT</b>	<b>Page 4</b>
<b>4. PANEL DESCRIPTION</b>	<b>Page 4</b>
<b>5. JOB PREPARATION</b>	<b>Page 5</b>
<b>6. JOB LAYOUT</b>	<b>Page 5- 6</b>
<b>7. INSTALLATION</b>	<b>Page 7-14</b>
<b>A) COMPARTMENT PANELS</b>	<b>Page 7-10</b>
<b>B) DOORS / JAMBS</b>	<b>Page 11</b>
<b>C) FINISH WORK</b>	<b>Page 12</b>
<b>D) FINAL INSPECTION</b>	<b>Page 13</b>
<b>E) OPERATIONAL MAINTENANCE</b>	<b>Page 14</b>

## 1. SAFETY

**Safety is the condition of being safe from undergoing or causing hurt, injury, or loss.** The concept of safety awareness is being conscious of your surroundings and making changes to the workplace to assure that injuries and property damage do not occur.

Please follow these safety guidelines when installing walk-ins:

- The following Personal Protective Equipment (**PPE**) is required when installing walk-ins:
  - Hard Hats
  - Safety shoes per OSHA guidelines.
  - Safety Glasses
  - Protective Clothing- long pants and long sleeve shirts should be worn.
  - Safety Harnesses must be worn when working on elevated surfaces.
  - Protective Gloves
  
- A certified electrician must do all electrical wiring.
- Keep work-site free and clear of debris.
- Use proper lifting techniques and ASK for HELP when needed!
- **USE COMMON SENSE; BE AWARE OF YOUR SURROUNDINGS.**

Each job site is different, there may be other safety items required by the General Contractor. Always check with the General Contractor to make sure that you comply with all job-site rules.

## 2. RECEIVING INSTRUCTIONS

### ***Upon receipt of shipment:***

1. Examine shipment for obvious damage.
  - a. The carrier and receiver must report the product damage on the delivery receipt and both parties must sign.
2. For missing or replacement parts, contact **Thermalrite** immediately
3. Fax a copy of delivery receipt to **Thermalrite (909)-605-6413** Attention: Freight Claims.

Receiver must notify **Thermalrite** of any concealed product damage within **10 days** of receipt of shipment. Original packaging material from the damaged item must be retained pending disposition of the damaged item.

## 3. PRODUCT UNLOADING / PREPARATION













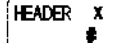







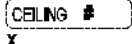
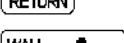

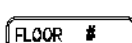
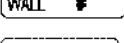
Each pallet will contain a packing list for all panels included on that pallet.

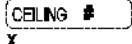
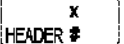
A quick review of the panel layout will serve as guide for unloading panels. The hardware box contains the panel layout drawing.

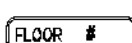
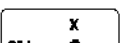
Select corner, t-walls, jambs, headers, sills, etc. and separate from standard wall panels such as 47" and 23". This will reduce handling, save labor and reduce damage.

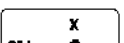
#### 4. PANEL DESCRIPTION

Panel Installer shall review each drawing (provided in the hardware box) to familiarize with the symbols and panel layout for each compartment. (SEE KEY BELOW)

SYMBOLS	 THERMOMETER / DIAL	<b>CAM/PIN MARKERS</b>		<b>PANEL MARKERS</b>		
	 THERMOMETER / DIGITAL	L  LOCK (WALLS)	 HEADER X		 CORNER #	
	 VENT - PRESSURE RELIEF PORT	P  PIN (WALLS)	 LEFT JAMB		 RIGHT JAMB	
	 PILOT LIGHT SWITCH 120v	 LOCK (CEILINGS)	 CEILING #		 RETURN	
	 PILOT LIGHT SWITCH 3-WAY 120v	 PIN (CEILINGS)	 FLOOR #		 WALL #	
	 FLUSH MOUNT HANDY BOX	 LOCK (FLOORS)	 X		 X	
	 T-MOLDING - FACTORY INSTALLED	 PIN (FLOORS)	 X		 X	
	 INCANDESCENT VAPOR PROOF LIGHT - MOUNTED		 X		 X	
			 X		 X	
			 X		 X	

Panels are tongue and groove construction, with urethane foamed in place insulation. Each panel joint has double gaskets to provide maximum sealing efficiency.

Cams operate from the interior of walk-in (in most cases); the cam (tongue) will be on the right of the panel and rotate clockwise to lock. Some conditions require the cam (tongue) to be on the left side of the panel for those cases the cam will rotate counterclockwise to lock.

#### 4. JOB PREPARATION

- Check the stability of the floor.
  - All walk-ins must be placed on a stable foundation. Movement of the floor under the walk-in because of soil conditions, freezing / thawing, or other reasons can cause damage to the walk-in. Such damage is not covered by our warranty.
- Check to see if floor is level. **A LEVEL FLOOR IS CRITICAL.**
  - If the floor is not level, shims (not supplied) must be used as required under the alignment strip or panel floor to make the walls level. In some cases, sand leveling may be required, particularly for larger installations with uneven building floors.
- Check overhead area where walk-in is to be installed for any obstructions.
  - Any obstruction should be corrected prior to starting.

For indoor applications, it is the responsibility of the installer and the owner to make sure the walk-in has **proper ventilation and humidity control**. Maintaining a minimum space of 1" for Coolers and 2" for Freezers for air movement is critical for wall and ceiling surfaces. ***If inside conditions reach the dew point on outside surfaces of the walk-in, condensation will occur and the resulting damage would NOT be covered under panel warranty.***

#### 6. JOB LAYOUT

Check with the general contractor or building plan to establish an airspace between cooler and building wall (Ideal space is 3", Minimum 1" for cooler application and 2" for freezer).

- Make a chalk line at this point. If cooler is in corner of building, start there.
- Make chalk mark on base wall first (see diagram below).
- Make perpendicular line using measurements from diagram below.

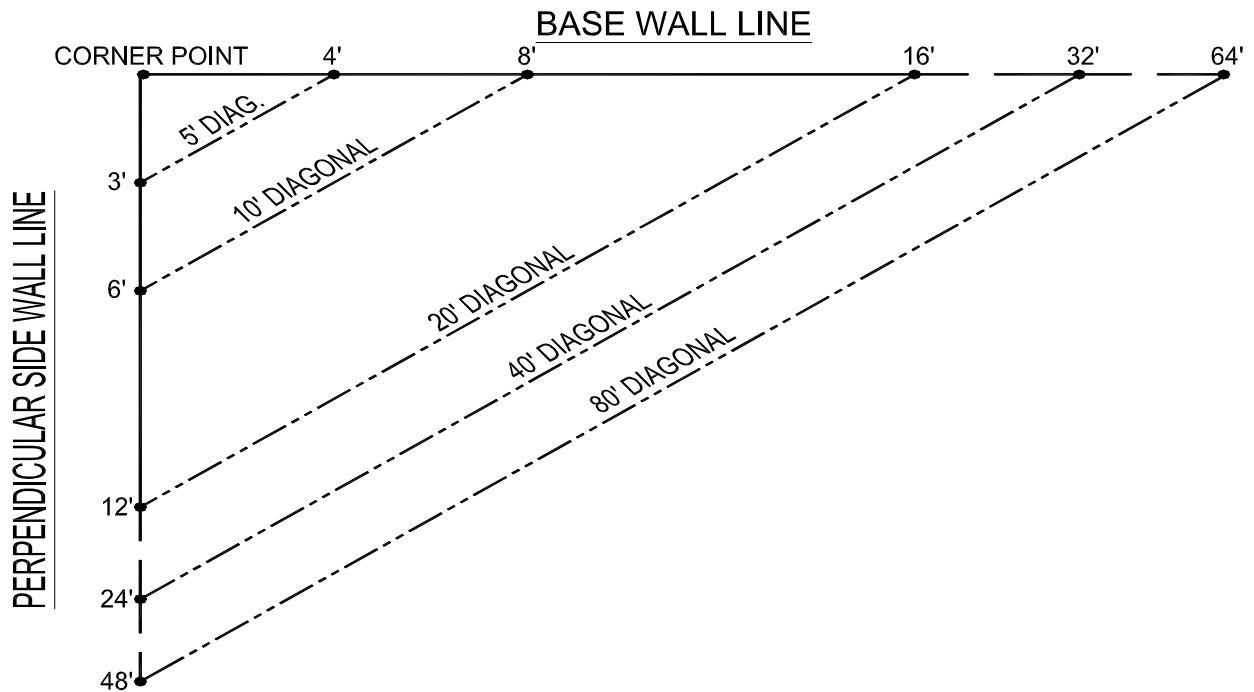

Once perpendicular lines are established:

- Make a parallel line. The parallel lines represent compartment outline.
- Measure corner to corner to make sure layout is square (measurements should be equal). If not, make all necessary adjustments.
- **Thermalrite** recommends beginning at the **high point** of the building floor.
- If compartment has a modular panel floor simply set floor on outline and level as you go.

- Floor Recessed in Building Slab (**fig.2**)

- Floor directly on Slab (**fig.1**)

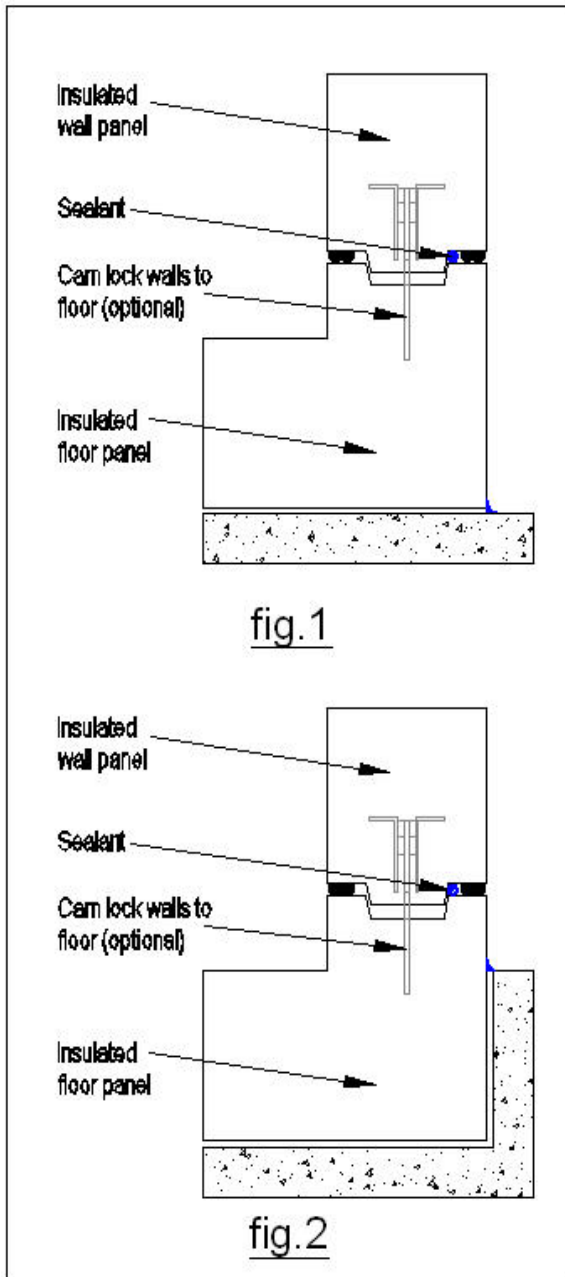

**Wall to Modular Panel Floor**

- STANDARD ALIGNMENT STRIP/SCREED
  - Center alignment strip based off the panel thickness from the compartment outline.
    - $3.5'' - 1\ 11/16''$
    - $4'' - 2''$
    - $5'' - 2\ 1/2''$
  - Wooden strip (**fig.3**); apply 3/8" bead of sealant as shown, drive pins or equivalent @ 24" O.C.
  - PVC extruded strip (**fig.4**); apply 3/8" bead of sealant as shown, drive pins or equivalent @ 24" O.C.
  - PVC U-shaped screed (Optional) (**fig.5**); apply 3/8" bead of sealant as shown, drive pins or equivalent @ 24" O.C.

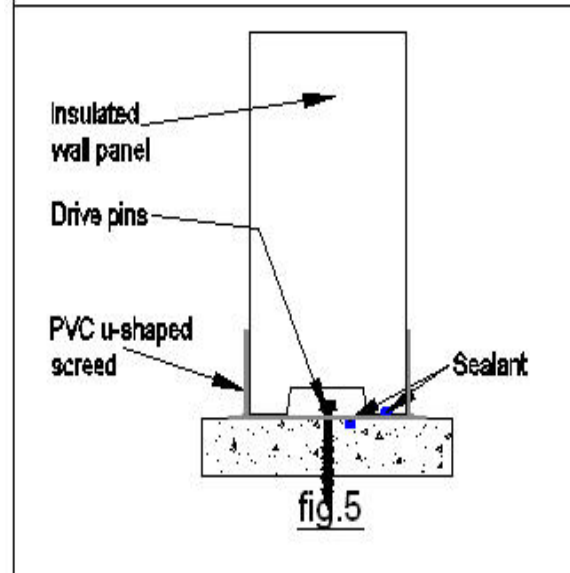
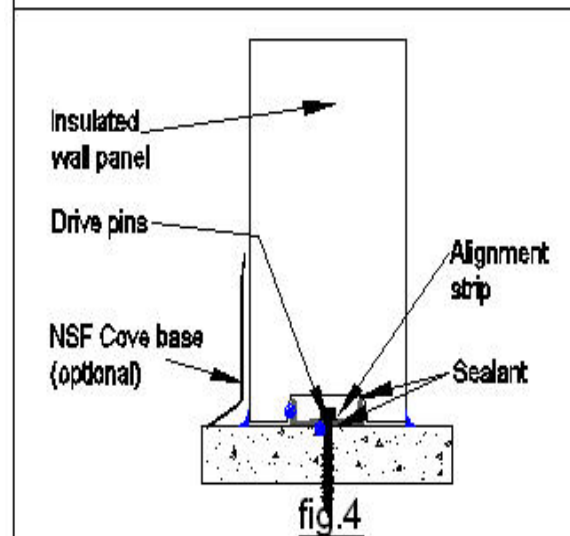
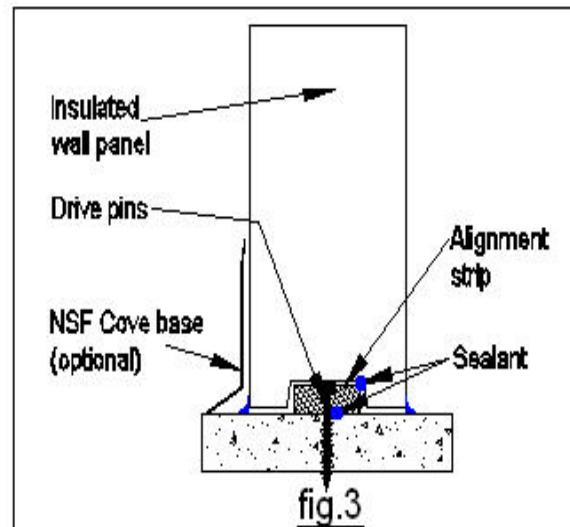
**Wall to Concrete Floors**

## 7. INSTALLATION

### A. COMPARTMENT PANELS

This sketch is a general section plan and does not necessarily depict your recently purchased product.

Floorless – (fig.6)

Modular Floor – (fig.7)

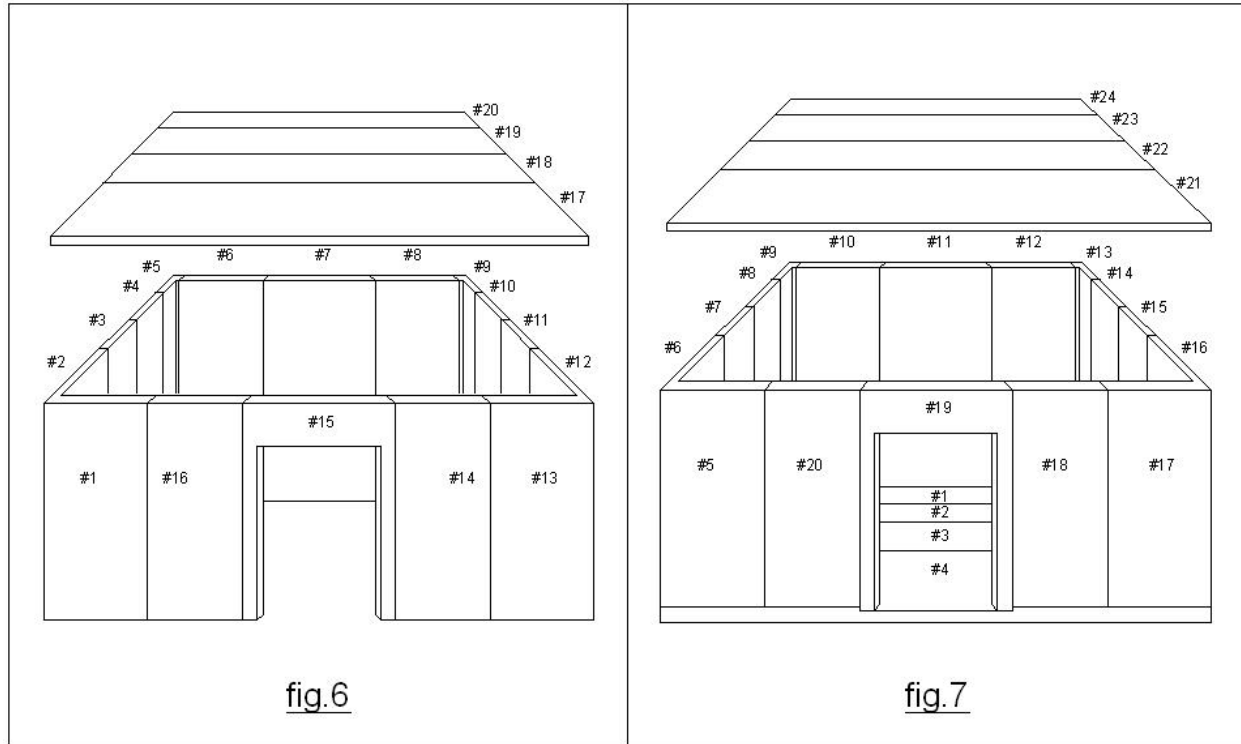

Panel numbers are found on the rails and correspond with number on the installation drawing.

- Position a corner panel and a perpendicular wall panel next to the building wall or the most inaccessible location.
- Each panel connects with “cam-lock” fasteners. Before activating cam-lock, move panels as close together as possible, line up tops of panels so they are flush, and must be level to one another. A hex wrench will be located in hardware box.

For larger jobs –

- Set three wall sides of compartment.
- Positioning ceiling panels towards the open end.
- Temporarily place the last ceiling panel on top of the ceiling panel adjacent to it.
- Complete the final wall of the compartment finishing with a corner panel.
- Finally position the last ceiling and lock into place.

**Wall to Ceiling Connections****Lag Down**

- 3/8" Lag bolt w/ washer @ 24" on center to connect to wall perimeter (supplied in hardware box).
- Trim cap, to be field installed with hex head screws (supplied in hardware box). – (**fig.8 & fig.11**)
- (**Fig.8**) – Wood Frame and Foam Rail applications
- (**Fig.9**) - Concealed (fascia) tops Wood Frame ONLY) (Optional)
- (**Fig.11**) – Foam Rail application ONLY

**Cam Down**

- (**Fig.10**) – Wood Frame and Foam Rail applications

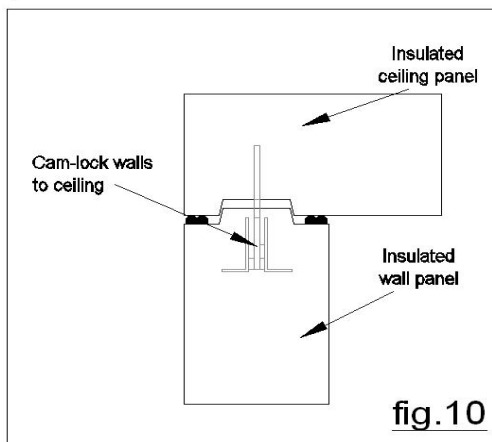
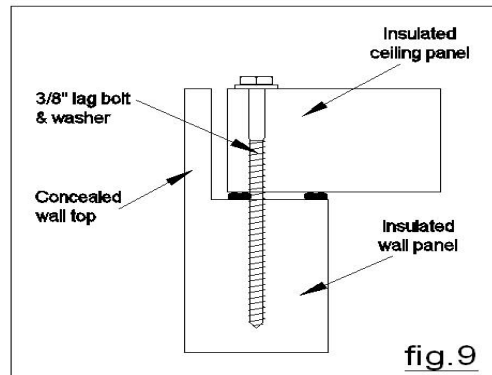
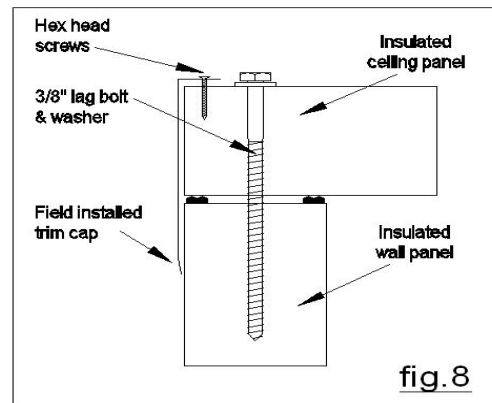

**SUSPENDED CEILING SUPPORT REQUIREMENTS**

Single unsupported span ceiling:

- 3 1/2" to 4" thickness ≤ 14'-0"
- 5" thickness ≤ 16'-0"

Suspended support brackets required

- Multiple spans of ceiling panels, **Thermalrite** supplies one bracket (**fig.12**) for each panel intersection.
- 3 1/2" to 4" > 14'-0" – **Thermalrite** supplies one bracket for each panel joint
- 5" > 16'-0" – **Thermalrite** supplies one bracket for each panel joint
- **Thermalrite** will supply 1" case-hardened nails per bracket
- Upon request **Thermalrite** can supply the 3/8" all thread rods (12'-0")
- **Thermalrite** Foam Rail ceiling panel brackets are slotted to fit over the locking pin so that cam-lock locks through bracket. Slot must be installed to line up with cam-locks per figure below.

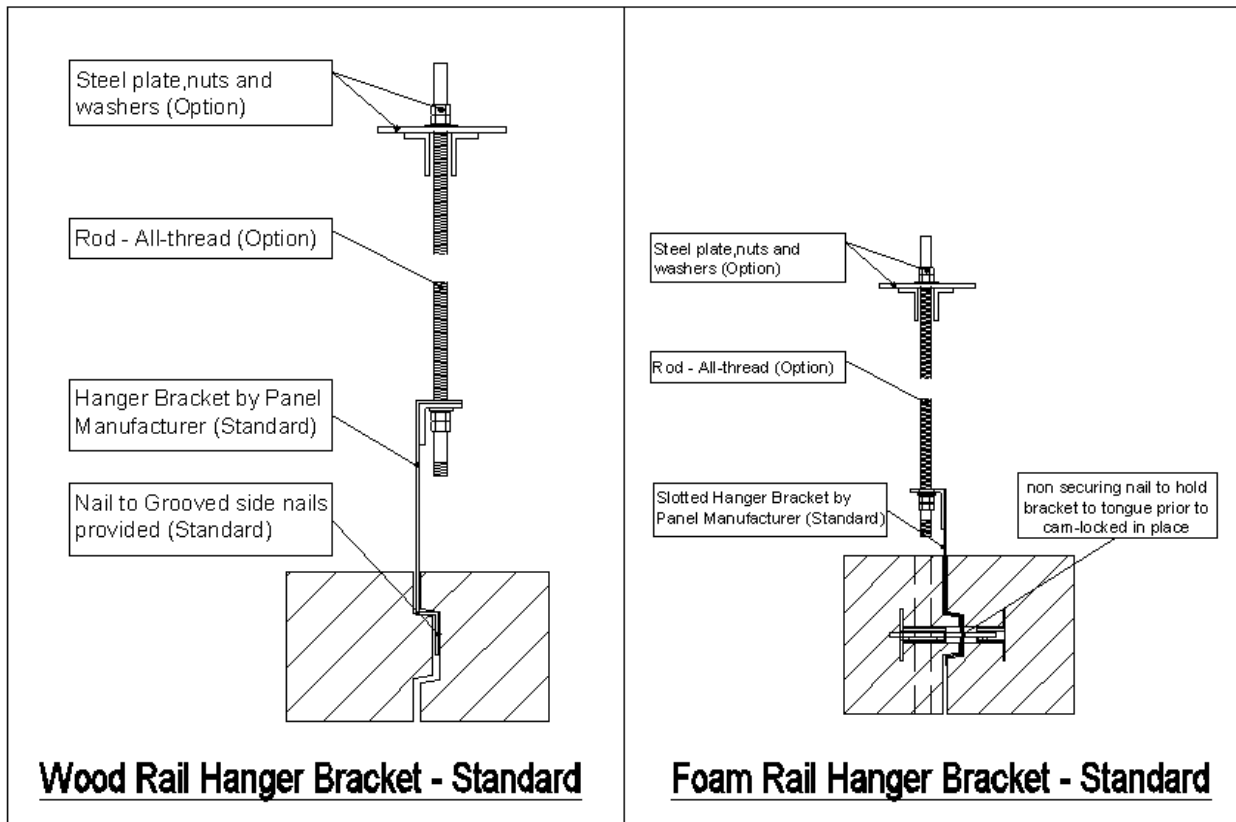

**BULKHEAD BRACING**

Header panels at bulkhead openings are to get additional support brackets (**fig.13**) attached at header panel and fastened to framing member in ceiling panel.

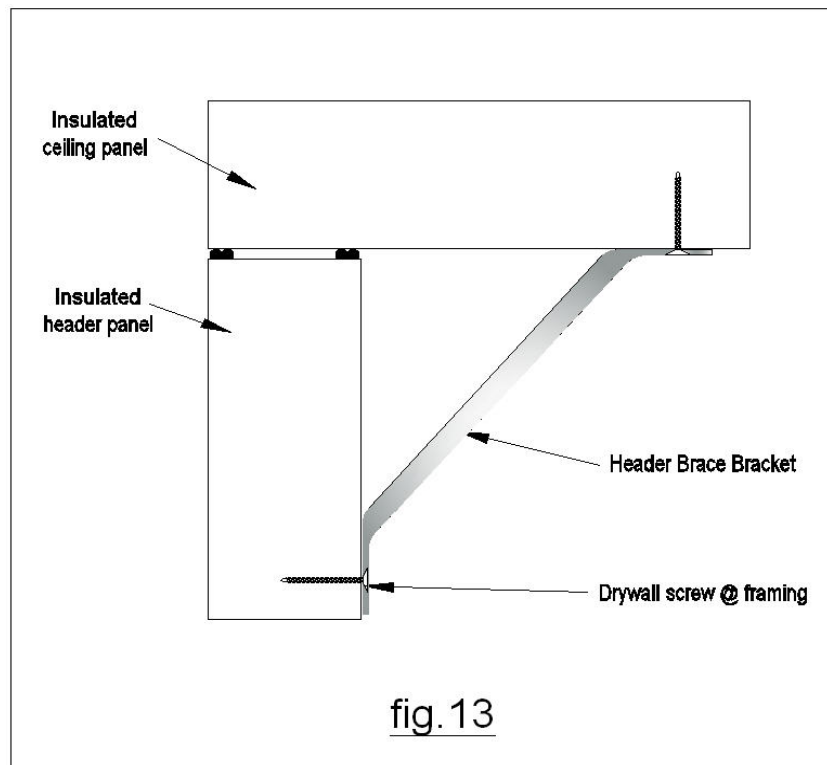
**\*\*\*\*\*CAULKING AND SEALING REQUIREMENTS\*\*\*\*\***

- All Freezer panel joints **MUST** be caulked with 3/8" cylindrical bead of butyl caulk at all wall to wall joints, ceiling to ceiling joints, wall to floor joints and wall to ceiling joints. Apply butyl caulk on the interior of the joint on the warm side. (**fig.14**)
- When it applies, ALL voids between ceilings and the walls with concealed tops (fascia) **MUST** be foam packed with spray foam (not provided) or it will **void the manufacturer's warranty**.

**OUTDOOR COOLERS AND FREEZERS**

- All compartments installed outdoors (both Coolers and Freezers) **MUST** have all joints between panels caulked on both the inside of the joint (on the warm side) and the exterior to prevent moisture from penetrating the joint. **THE INTERIOR SEAM SHOULD NOT BE CAULKED!** The caulk used on the exterior seam should be a silicone caulk with a rated life of at least 25 years. The caulk on the inside of the joint should be a low or no VOC butyl caulk. Be sure it is safe for your application. The cylindrical bead of caulk on both the inside of the joint and the exterior seam must be complete (NO GAPS) for the entire length of the joint and Minimum of 3/8" high to fill in the joint and to adhere to both sides of the joint when the panels are locked together. An annual inspection for gaps in the sealant is required for the life of the warranty; fill any gaps or breaks for it to remain in effect. (**fig.15**)

Installation Instructions  
Wood Frame & Foam Rail Panels

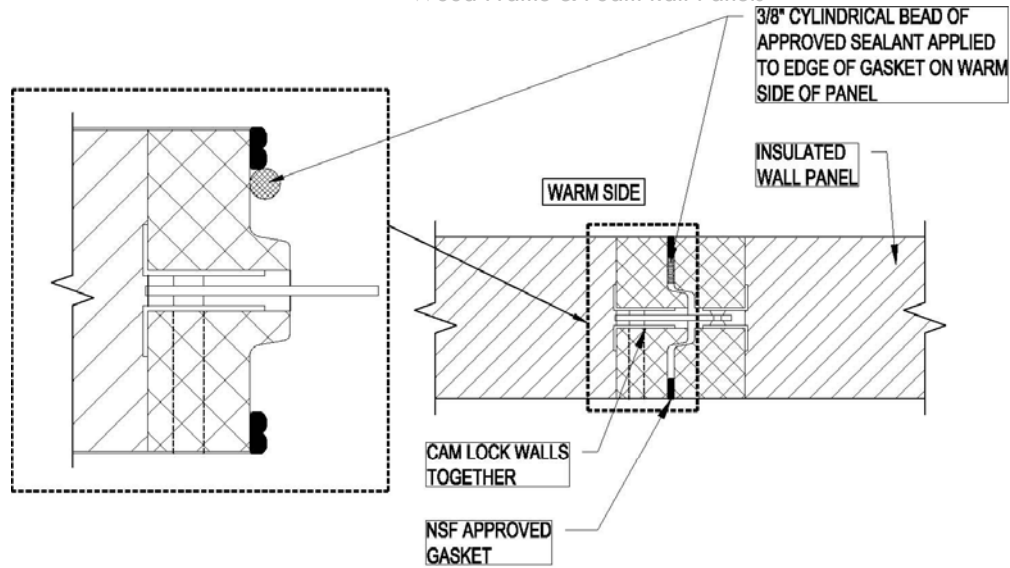

fig. 14: SEALANT/CAULK REQUIREMENTS - INDOOR LOW TEMP °F

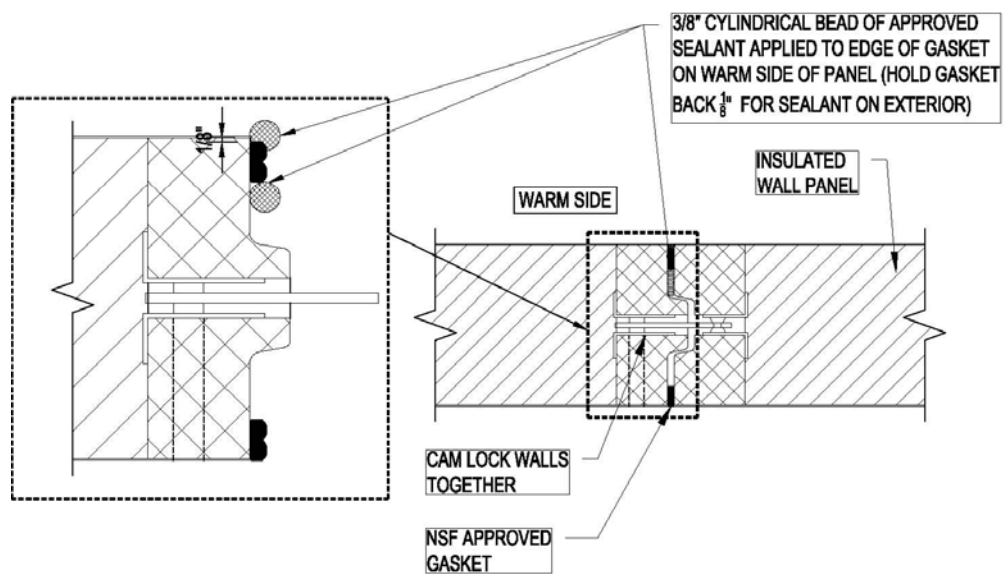
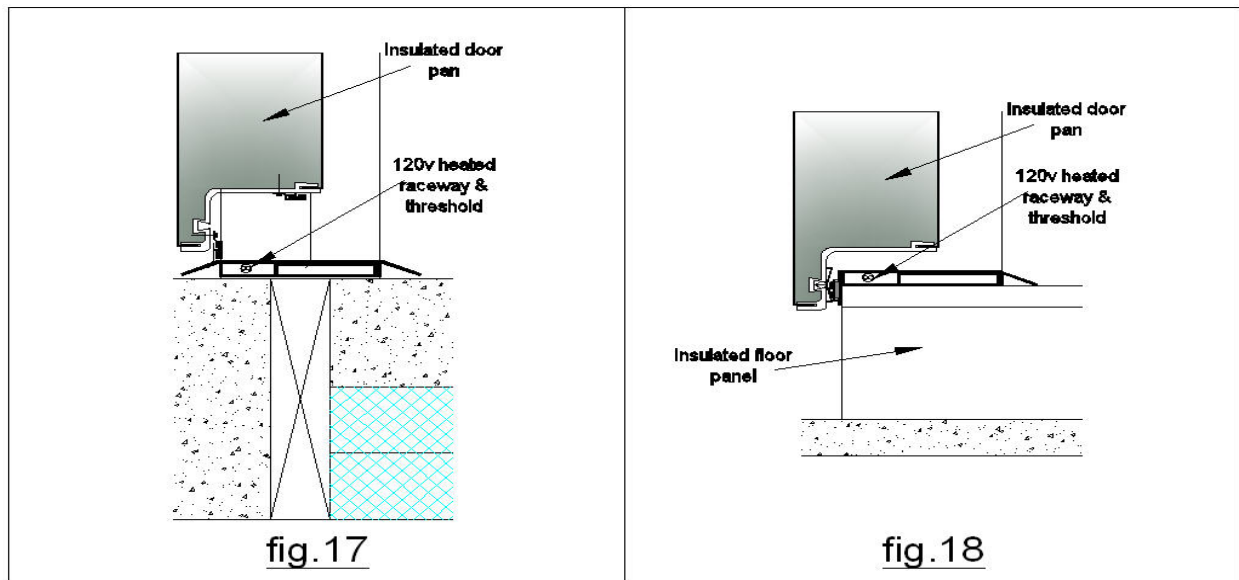

fig. 15: SEALANT/CAULK REQUIREMENTS - ALL OUTDOOR °F APPLICATIONS

## B. DOORS AND JAMBS

### FREEZER JAMBS - (fig 17, fig 18)

- Jambs are 120v pre-wired with an anti-condensation heater and ready for hook up by a certified electrician.
- To avoid damaging the heater wire, position the threshold properly before securing to the floor.  
**WARNING!!!DO NOT TURN ON HEAT WIRE UNTIL REFRIGERATION IS RUNNING, AS THE HEAT WIRE WILL SHORT OUT FROM GETTING TO HOT.**
- Install threshold before hanging the door.



### HINGED DOOR

Installing **Thermalrite** hinged door...

- The doorjamb must be level and plumb for proper door operation and seal.
- After carefully positioning the jamb, use a level and make any necessary adjustments.
- Hang door and check for fit and seal, prior to attaching ceiling panel to door wall.

**Please Note:** if the door is for a floorless compartment adjust the bottom door gasket accordingly.

### STABILITY BRACKETS – (fig.16)

Install jamb stability bracket to building floor

- Anchor the galvanized angle on each interior side of the opening (3/8" X 2 1/2" Kwik bolt)
- Then lag bolt angle each jamb (1-3/8" X 2")

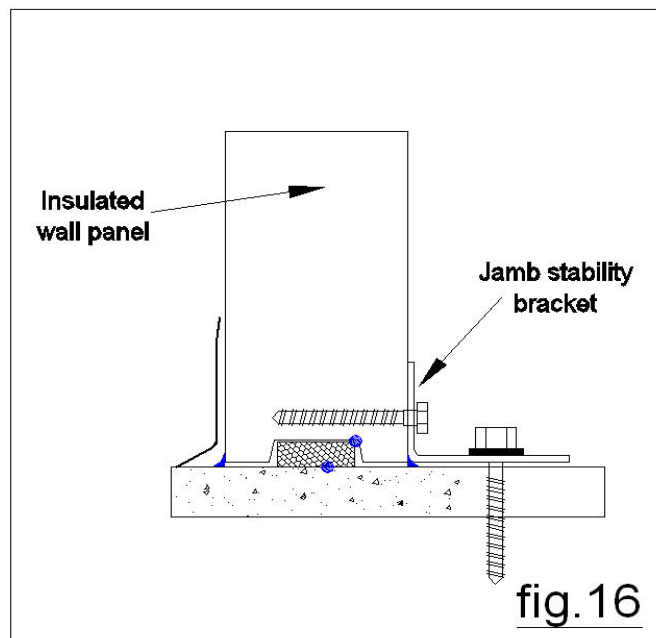

**C. FINISH WORK**

- Install vinyl plugs in each “Cam Lock” access hole. Push in plug with thumb and gently tap in with hammer.
- Ceilings should have a bead of silicone caulk on interior where wall and ceiling panels meet for both coolers and freezers.

**CEILING CAP TRIM METAL**

Ceiling cap trim metal will be the standard on all overlap or cam-lock ceilings (see diagram). Drawings will indicate whether ceiling cap trim metal or ceiling caps are to be used. If trim metal is to be used, attach trim metal using  $\frac{3}{4}$ " #8 self-tapping hex head screws, which you will find in your hardware box.

**D. FINAL INSPECTION**

- All locks are engaged and wrench ports closed with cap buttons.
- Entrance door operated smoothly, closes, and seal properly.
- Thermometer indicates correct reading.
- All excess sealant is removed and residue wiped up with appropriate cleaner.
- Installation should be as NEC or as local codes dictate, for door and jamb wiring.

**E. OPERATIONAL MAINTENANCE**

**For years of trouble free service, the following steps should be taken:**

1. Wipe up spills with warm water and mild soap, **DO NOT USE HARSH DETERGENTS SOLVENTS OR ABRASIVE CLEANERS. Dry thoroughly to prevent ice formation.**
2. Use same procedure (as above) to remove dirt or fingerprints from wall surfaces. NOTE: If finish is stainless steel, wipe in direction of “grain”. **Dry thoroughly to prevent ice formation.**
3. Clean magnetic gasket (if applicable) regularly using a damp cloth.
4. Lubricate door hinge bearings with petroleum jelly when needed.
5. Periodically check all hardware fasteners to insure they are firmly anchored. If any part malfunctions, call **Thermalrite** for advice or, if necessary, replacement.
6. Do not store items on top of walk-in(s). This may result in condensation, which may damage walk-in panels. Any such damage will not be covered under warranty.
7. Periodically check the operation of the doorframe heater wire and heated vents. Ice forming around either of these openings may indicate that replacement is required. **BE SURE ELECTRICAL POWER TO HEATED VENTS and/or DOOR PERIMETER HEATER IS OFF PRIOR TO REPLACEMENT. All electrical work must be done by a certified electrician**
8. If door is not sealing properly, adjust the strike accordingly. Also, check to see that the door sweep gasket is adjusted properly.
9. The evaporator coil and condensing unit should be cleaned periodically with a soft brush and vacuum cleaner. Inspect the evaporator condensate pan and remove any debris.
10. **BE SURE THAT ELECTRICAL POWER TO THE REFRIGERATION SYSTEM IS OFF PRIOR TO INSPECTION AND CLEANING.**

6/2/2011

Installation Instructions  
Wood Frame & Foam Rail Panels